

AEIC SOLUTIONS

Your Preferred Partner in

- ☛ Automation (Process, Factory & Building)
- ☛ Electrical (Energy, Power Quality & Engineering)
- ☛ Inspection (Safety & Electrical)
- ☛ Control (Audit, Management & Improvement)



Address: 14 Robinson Road, #13-00
Fareast Finance Building Singapore 048545

Hotline: +65 98738938
Fax: +65 67293758

Email: aeics@aeics.com
Website: www.aeics.com

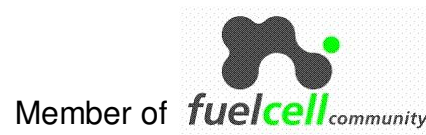

Energy saving solutions for Home, Offices and Commercial Buildings

ABOUT AEIC SOLUTIONS

Established in Singapore, AEIC SOLUTIONS (AEIC) provides one-stop Technical & Engineering Solutions and Services on Automation, Electrical, Inspection and Control in the field of Process Industries and Commercial Buildings, especially on Energy Conservation & Saving, Electrical Design & Engineering, and Building Automation and CCTV & Security System to the region.

Our competencies include technical, engineering and services on Electrical, Automation and management. AEIC serves various industries including the Property Management, Facilities Management, Processing Industries and Semiconductor sectors.

CORE VALUE

PICTq -

- ⇒ Productivity
- ⇒ Integrity
- ⇒ Customer Focus
- ⇒ Teamwork
- ⇒ Quality

OUR VISION

To be recognized as a leading solutions provider on Automation, Electrical, Inspection and Control in the region with an indisputable reputation for superior customer service, innovative products and services, flexible and efficient operations that create and maintain a financially strong organization.

OUR TEAM

Our experts will assist you on conceptual study and investigation, then provide you economical solutions with high efficiency, as well as implement the project and hand over to you with professional guidance.



OUR COMMITMENT

OUR QUALITY SOLUTIONS MEET WHAT YOU NEED.

OUR SERVICES

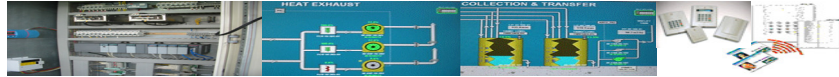



AUTOMATION



-  **Process Automation** – Production Lines and Robotic Equipment, etc.
-  **Factory Automation** – Computer Integrated Manufacturing (CIM) and Facilities Monitor & Control System (FMCS), etc.
-  **Building Automation** – Intelligent Door Access and Barrier Gate, Public Address System, CCTV and Security System, Lift integrated Supervisory System, etc.





ELECTRICAL



-  Electrical Design and Installation.
-  Energy Conservation and Energy Efficiency / Saving Solutions.
-  Power Quality Solutions for Hi-tech Industries with Analysis and Improvement.
-  UPS, CPS & DCS application.
-  Engineering Solutions and project Management.





INSPECTION

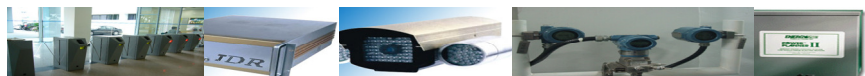

-  HV/LV **Loaded Live-Test** and Inspection with patented technology – “Live-Loaded Non-intrusive Predictive Maintenance”.
-  HV/LV **Live Inspection** with Infrared Thermograph technology.
-  Partial Discharge Measurement on HV/MV electric power system.
-  Safety audit, Investigation and analysis of electrical incident – FMEA & TPS (8D).

CONTROL



-  Energy Management Audit and improvement solution.
-  Design and installation of I&C System.
-  Security & Safety Audit, Control and improvement.
-  Project plan and Management.

POWER SAVER

AEIC provides total energy saving solutions to our valuable customers with our recommended products, technologies and value engineering.

Concept of Product:

Power Saver provides you a Result-Oriented solution on Energy Saving. Power Saver will provide an economical and reliable solution to the built in inefficiencies of AC motors.

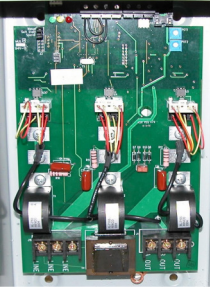

The Power Saver equips a Digital Signal Processor with patented software of energy management and control which senses the current and voltage and precisely control power output, and let the power output match with the load request. This can save your money on the operation of the induction loads through reducing electricity wastage by:

- ✓ Improving the induction load efficiency.
- ✓ Modulating the power output according to the loading.

Power Saver Principle

Power Saver Principle

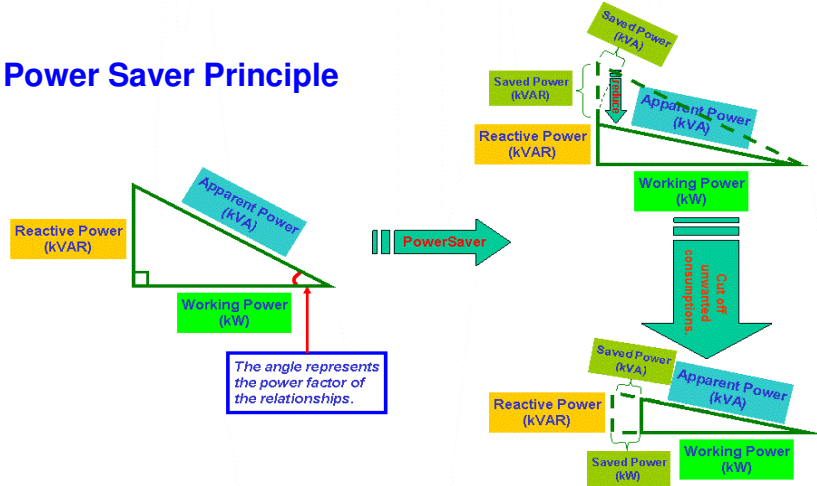

Product Efficiency:

Power Saver provides additional and valuable solution on Energy Saving for the devices which results can not meet your requirement, and lets you get saving up to 40%. The results have been tested by the Authorities, Labs and Clients. The typical performance of Power Saver is shown below.

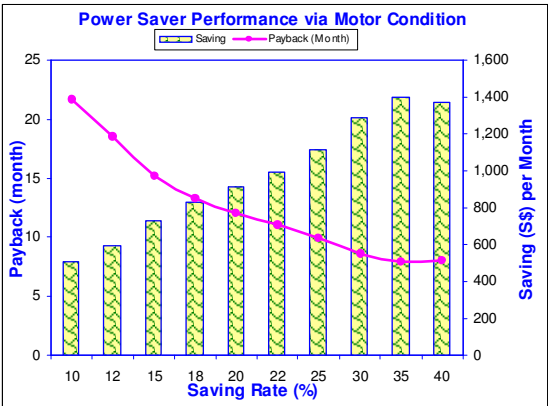

Our Ref : 55589193/51515151

PSB Test Report

PSB Corporation

Results
Ambient temperature = (23 ± 2)°C

Electrical Parameters	Before Installation of 'ETI Power' Model No. : EPS20 Energy Saving Device (Measured Values)	After Installation of 'ETI Power' Model No. : EPS20 Energy Saving Device (Measured Values)
Voltage (V)	240.59	240.65
Current (A)	5.6147	3.4629
Power Factor	0.4238	0.5473
Active Power (W)	672.81	457.64
Reactive Power (kVAR)	1222.50	698.59
Apparent Power (VA)	1351.40	833.45

Remark
Tests was performed to compare with and without 'ETI Power' Model No. : EPS20 Energy Saving Device.

SIM TEW QEE
 TESTING OFFICER

Total Energy Saving: 38.33%
Reactive Power Reduced: 42.87%
Current Reduced: 38.32%
Power Factor Increased: 29.14%

YEE CHEONG IH
 ASSISTANCE VICE PRESIDENT
 SWITCHGEAR & ACCESSORIES
 PSB TESTING

Page 3 of 8

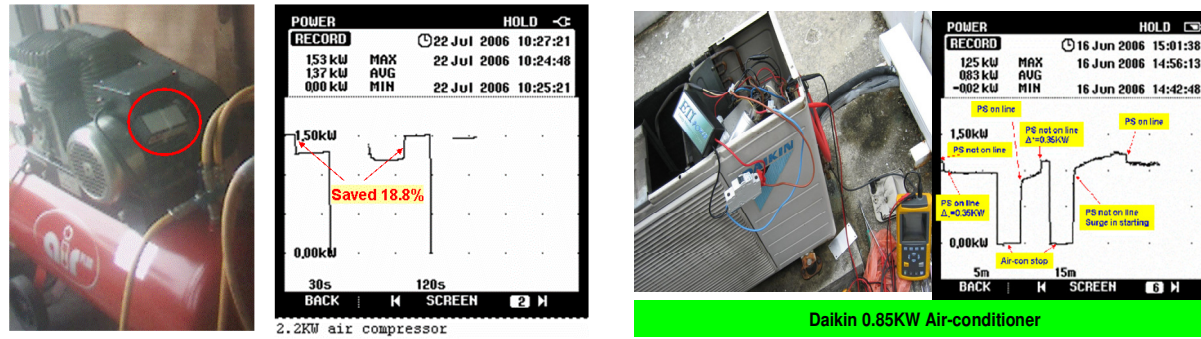
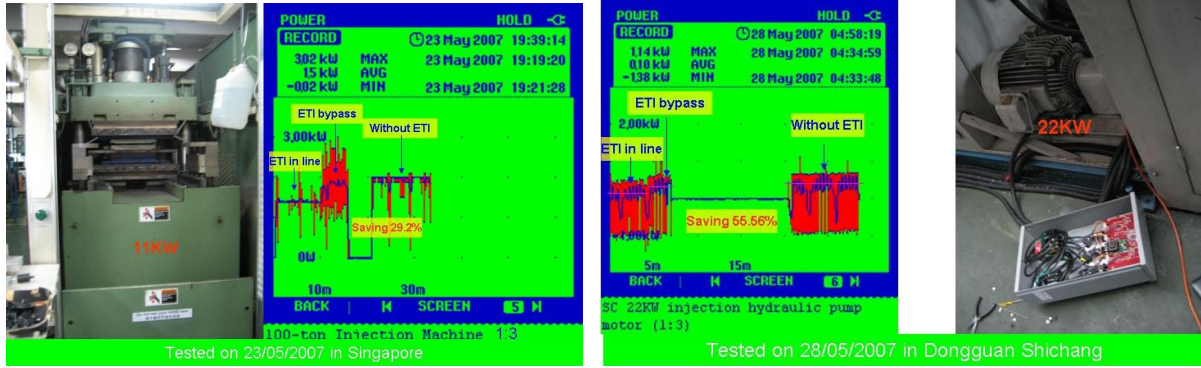

Power Saver Application Test (USA)

S/No.	Application	Motor Spec.	Without Power saver			With Power saver			Calculated Saving
			V rms	A rms	P kW	V rms	A rms	P kW	
1	Van Dorn 1500 ton Motor	75 HP, 460V, 3 Phase	472	48.52	22.90	471	39.7	18.70	51.26%
2	25HP Motor	460V, 3-Phase	483	29.9	22.51	463	25.6	15.60	30.70%
3	Hotel Window A/C	Single Phase	212	12.3	2.61	202	9.8	1.98	25.59%
4	Trane A/C Unit	Single Phase	229	13.7	3.14	221	12.1	2.67	23.00%
5	Water Cooler	Single Phase	120	1.77	0.21	105	1.59	0.17	21.40%
6	30HP Exhaust Fan	3-PH, 460V	460	-	15.10	430	-	12.40	17.88%
7	Supermarkets - Soft Drink Cooler	Single Phase	130.9	-	0.46	111	-	0.38	17.39%
8	10HP Blower Motor	3-PH, 415V	415	-	105.15	377	-	99.50	14.89%
9	200HP Air Compressor	3-PH, 460V	458	-	112.10	439	-	98.20	12.40%
10	Car Dryer Blower	50HP, 460v, 3-Phase	482	-	39.67	459	-	34.85	12.15%
11	Pool Pump Fan	Single Phase	236	8.75	2.07	230	7.9	1.82	12.01%

Power Saver Application Test (Asia)

S/No.	Application	Motor Spec.	Without Power saver			With Power saver			Calculated Saving
			V rms	A rms	P kW	V rms	A rms	P kW	
1	Oil Pumping Machine	37KW, 380V, 3 Phase							55.56%
2	Hydraulic Motor	24KW, 380V, 3 Phase							52.63%
3	Carpark Exhaust Fan	240V, Single Phase							36.90%
4	Grinding Machine	400V, 3 Phase							32.90%
5	Air handling Unit	400V, 3 Phase							30.00%
6	Injection Modulding Machine	11KW, 400V, 3 Phase							29.60%
7	Air-con in HDB Flat	2.5kW, 230V Single Phase							29.40%
8	2-roll Mill Machine	400V, 3 Phase							26.30%
9	Condensor Water Pump	400V, 3 Phase							25.50%
10	Air Compressor	240V, Single Phase							18.80%
11	Kitchen Exhaust Fan	240V, Single Phase							14.70%
12	Condensor Water Pump	55kW, 400V, 3 Phase							12.50%

Power Saver's Benefits for Users:

“Immediately save energy and money after starting to use POWER SAVER” and determine your motor potential problem to save maintenance cost.

- ✓ Quick Payback (return on investment) – typically at **1.5 years** period based on electricity savings alone.
- ✓ Real time motor supervision and on line fault detection (optional)
- ✓ **Direct Savings (tangible)**
 - Reduce the electrical demand and consumption.
- ✓ **Indirect Savings (Intangible)**
 - Extend the lifetime of electric equipment (eg. motor) by reducing:
 - The operating temperature – cooler running.
 - The internal friction of bearing.
 - The noise and vibration.
 - Reduce maintenance cost
 - Reduce equipment breakdown and save repair costs.
 - Increase motor efficiency and reliability
 - Soft start (reduce inrush / high start current) / soft stop.
 - Improve the power factor.
 - Balance the voltage between phases.
 - Reduce downtime cost.
 - Optimize utility demand.

Easy Installation:

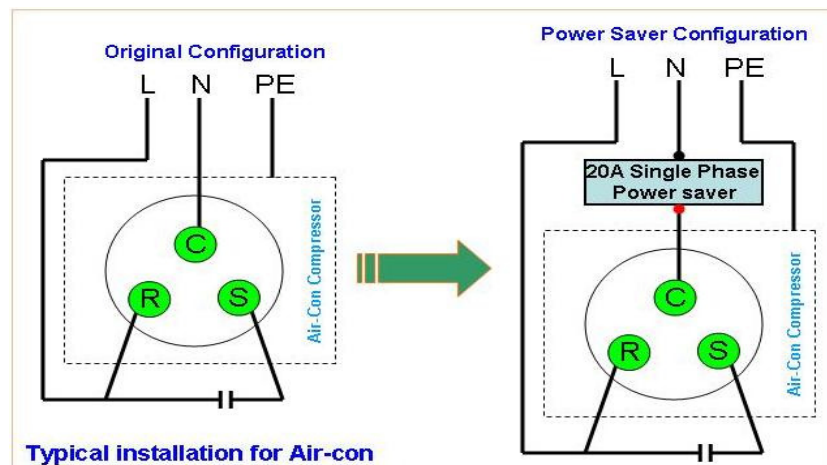

Typical Application and Saving:

<u>Equipment</u>	<u>Industries</u>	<u>Savings</u>
Car-park Exhaust Fan	Hospital	36.90%
Grinding Machine	Manufacturing Plant	32.90%
Split Unit Air-con	HDB Flat	26.92%
Air Handling Unit (AHU)	Aviation Facility	22.40%
Split Unit Air-con	Service Apartment	20.81%
Elevator	Manufacturing Plant	19.23%
Air Compressor	Manufacturing Plant	18.80%
Escalator	Shopping Centre	15.50%
Kitchen Exhaust Fan	Coffee Shop	14.70%

Air-con Saver



Application:

1. Air-con used in house, commercial building, office, hotel and hospital, etc.
2. FCU (Fan Coil Unit is hooked up thermal sensor) used in buildings and factories.
3. Fridge used in house, office, hotel, restaurant and hospital, etc.
4. Ice maker used in house, hotel, restaurant and hospital, etc.

Efficiency:

Save electricity up to 30% and vary with equipment condition. See below test trend for Nation two-system Air-con (got 26% saving while applied one Air-con Saver to one fan coil unit, another fan coil unit is running as normal). **We guarantee 10% saving** for non-inverter air-con.

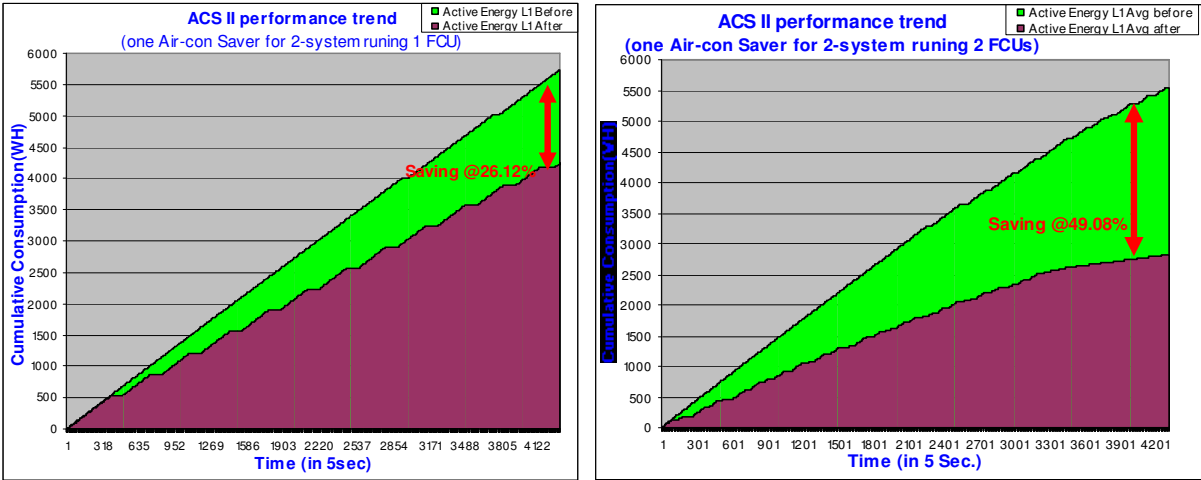

Principle:

Air-con Saver applies fuzzy-logical technology to simulate human thermal comfort and enhance the refrigeration efficiency by optimizing the operation curve of compressor, as well as to control compressor to adjust cool air output and prevent the air over-cooled to waste energy, and further to save energy.

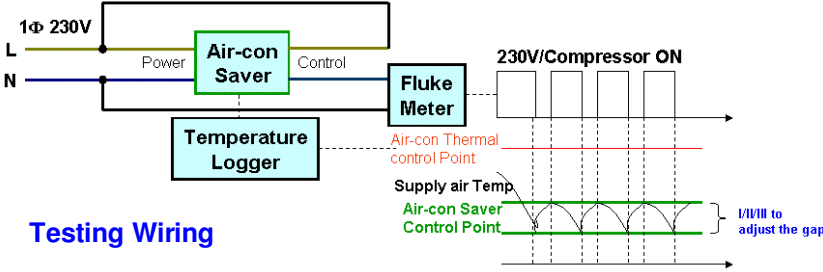

It's carried out as follows:-

1. Save electricity thru controlling low limited temperature. According to the operation curve of air-con compressor, when compressor runs to the low limited temperature, the whole temperature will rise, the current and the energy expenditure will also increase. However, the cooling temperature will never go down any more or very less. In this situation, the Air-con Saver will control the compressor to stop, and to save the energy that will be wasted on. In the meanwhile, the compressor is completely cooled down, and its reliability will be increased.

2. The cooled refrigerant still maintains in the compressor system after compressor stopped. As the cooling fan continues to run while compressor stopped, the air from cooling fan still keeps cool and maintain the room temperature. When the air temperature rises to certain level, the simulator of Air-con saver will control compressor to start up for next cycle, and so on. This does avoid compressor frequently starting up, and the energy is saved successfully.

3. Avoid frequently starting up the compressor. The compressor's start and stop are controlled by protractor. In the state of heating, it stops when the temperature is higher than the targeted setting, and starts while lower. In the state of cooling, it starts when the temperature is higher than the targeted setting, and stops while lower. Actually, the work cycle is a few minutes. So frequent to start and stop compressor, it will bring in rush current impact and huge energy expenditure. Whereas the working cycle of air-con saver is scores of minutes, it avoids frequent rush current impact to compressor and extends compressor's lifespan.

Note: This saving efficiency is adjustable through a "saving selection" switch which is classified in 3 grades. When the switch is selected in different grade, the saving efficiency will be different as 20%, 25% or 30% for the air-con with middle grade of efficiency. Air-con Saver also equips a bypass switch to switch saving mode to normal operation mode.

Ease of Installation as below instruction:-

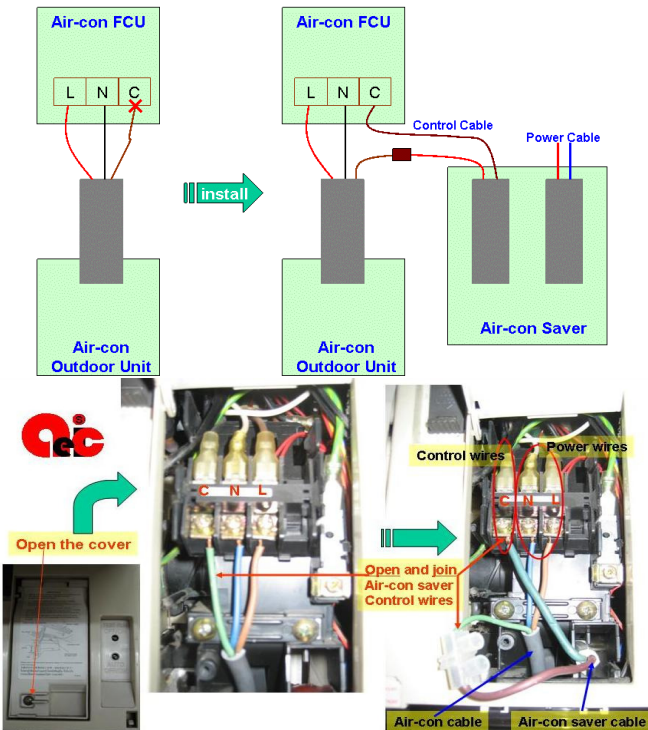

Air-con Saver Test Result:-

Energy Saving Verification



Client:	CPG Facilities management Pte Ltd	Contact Person:	Mr. Azrin / Mr. Edward Tan
Address:	30 Bedok North Road, Bedok Police Divisional HQ	Contact Number:	+65 97875478
Equipment Name:	Panasonic Split air-con	Equipment Location:	Server Room, Level 2
Motor Type/Model:		Motor Specs:	
Project:	Air-con Saver for Split unit	Energy Saving Solution(s):	Air-con Saver - ACS-II
Instrument:	Fluke 1735 Power Logger (Model)		

Before Energy Saving Solution Applied										
Data Collect time		Real Power			Power Factor			Reactive Power		
Date	Time	Meter Reading	Usage	Remarks	Meter Reading	Average	Remarks	Meter Reading	Usage	Remarks
		KWH	KWH					KVAh	KVAh	
24/04/08	12:24:26	39094	46.6056	Rainy		NA			NA	

After Energy Saving Solution Applied										
Data Collect time		Real Power			Power Factor			Reactive Power		
Date	Time	Meter Reading	Usage	Remarks	Meter Reading	Average	Remarks	Meter Reading	Usage	Remarks
		KWH	KWH					KVAh	KVAh	
23/04/08	12:52:04	36567	36.0165	Sunny		NA			NA	

Project Saving:	Real Power	Power Factor	Reactive Power
S = (Q1-Q2)/Q1 X 100%	22.72%		

10.58737 kwh.

Recorded and reported by:
 Wynn Chen
 Name: Wynn Chen, Signature: [Signature], Date: 25/04/08

Witnessed and accepted by:
 Mr. Azrin
 Name: Azrin, Signature: [Signature], Date: 25/4/08

AEIC Solutions

Client: CPG Facilities management Pte Ltd
 M/S: Bedok Police Divisional HQ



Other Energy saving products/solutions:

Lighting Retrofitting

In some instances replacing old equipment with newer, more energy efficient equipment is warranted. In many cases, local utilities will offer rebates for such upgrades and the energy savings can be dramatic. For example, inefficient older T-12 and T8 fluorescent lamps with electro-magnetic (EM) ballasts are replaced by more modern electronic ballasts with T-8 or T-5 lamps; HID, HPSL & HPM can be replaced with high efficiency lamp, such as HF-EDL. This treatment alone can cut the electric bill for the lights by 30% - 65%!

1. T5 adaptor for T8 fluorescent tube

T5 adaptor applies advanced T5 technology to retrofit T8 fluorescent tube in simple way. If you are concerned for the retrofitting cost, we recommend you to replace the T8 fluorescent light with the T5 adaptor. This treatment alone can cut the electric bill for the lights by 25% to 45%!

1.1 T5 adaptor Test Result

Testing tube	Nominal Watts	Running Watts*	Running Pf	Lux**	
				Range	Range
T8 Phillips	36+	42	0.38	175-181	178
T5 adaptor	28+	24	0.97	173-177	175
T5 adaptor to T8	-8+	-18	+0.59	(-2)-(-4)	-3
	-	-42.86%	+155.26%	-	-1.6%

* Watts are including consumptions of tub and ballast for single tube. The result will vary with light conditions.

** Lux is measured at 1.5 meters direct under the tube at the starting time.

1.2 T5 Adaptor Installation

Simple Replacement Method



DESCRIPTION

Replaceable T5 Energy Saving Batten - the unique method to convert existing T12 and T8 fittings into the next generation of T5 Tube. The in built T5 electronic ballast can also be working independently and replace the T8 fittings that driven by electronic ballast.

ADVANTAGE

Energy Saving: Save up to 50% energy over existing lighting system
 Save Money: Save your electricity charge and maintenance fee.
 Simple Replacement: Not require to interrupt normal operation during replacement
 Easy Installation: 120 pcs/ hour

APPLICATION

Suitable for the replacement of T8 Batten, Troffer driven by electromagnetic ballast or electronic ballast.

OUR COMMITMENT

Improve lighting quality (raised colour rendering)
 Improve lighting environment (without noise & flicker)

2. High Frequency Electrodeless Discharge Lamp (HF-EDL)

HF-EDL applies techniques of Electromagnetic induction and discharge of fluorescent gas to ionize the fluorescent gas to plasma. The fluorescent powder will generate visible light after it is stimulated by UV that is generated by stimulated plasma.

2.1 Advantage:-

1. Long lifespan – $\geq 60,000$ hours
2. Short start and restart time – < 0.5 seconds
3. High power factor – ≥ 0.98
4. Low surface temperature – $< 90^{\circ}\text{C}$
5. High Stability – Flicker free
6. Wide voltage range – 125-265V
7. High Ra – > 80
8. Low maintenance fee – Mostly free maintenance in first 3 years

2.2 Advantage – Lifespan compares with HID:-

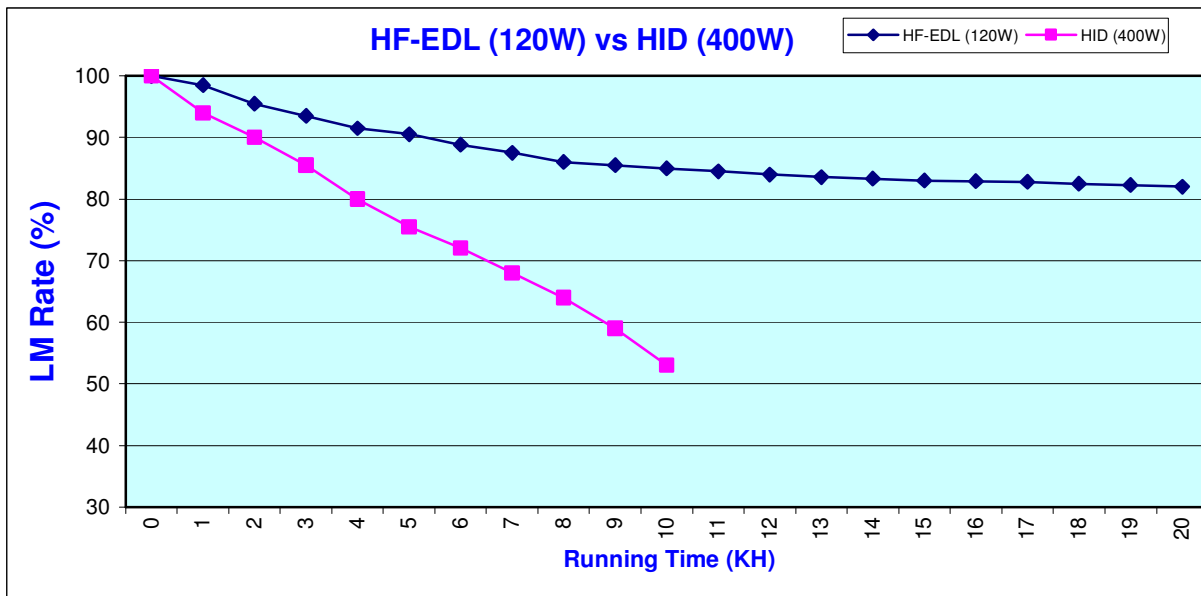

2.3 Schematic for work principle

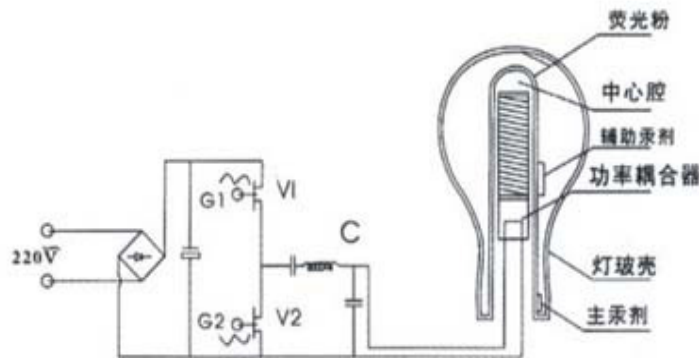

HF-EDL work principle

Radiant Barrier

Radiant barriers are installed in homes—most commonly in attics—to reduce summer heat gain and winter heat loss, which helps lower heating and cooling costs. The barriers consist of a highly reflective material that reflects radiant heat rather than absorbing it.

Heat travels from a warm area to a cool area by a combination of conduction, convection, and radiation. Heat flows by conduction from a hotter material to a colder material when the two materials touch. Heat transfer by convection occurs when a liquid or gas is heated, becomes less dense, and rises. Radiant heat travels in a straight line away from the hot surface and heats anything solid as the wave of energy hits it.

When the sun heats a roof, it's primarily the sun's radiant energy that makes the roof hot. A large portion of this heat travels by conduction through the roofing materials to the attic side of the roof. The hot roof material then radiates its gained heat energy into the cooler attic (some of the roof's heat will radiate in other directions too). A radiant barrier reduces the radiant heat transfer from the roof to the attic space.

- Fiberglass re-inforced (perforated) aluminum foil insulation
- Fire retardant
- Reflects 95% of radiation heat
- Perforated aluminum foil radiant barrier to eliminating sweating
- Use for attics, roof and walls
- Easily stapled into place in attic on ceiling joists or rafters, sealed with aluminum tape
- Adhesion Good on clean and dry surface
- No Discoloration Resistance Excellent resistance to water, water vapor, oxidation and weathering



The PowerSaver Reactive Power Correction System

The PowerSaver is a product with almost universal application, used to reduce the energy consumption and improve power quality on all types of AC motors (machinery, air conditioning, refrigeration, etc.). It does this by cancelling a portion of the power normally drawn by these loads. And, more importantly, it does so without negatively affecting horsepower, speed, or reliability.

The PowerSaver reduces the wasted energy normally used by these motors by aligning the phase angle of the supplied voltage and current. This saves energy, reduces heat generation inside motors, frees up new electrical capacity within a facility, and produces a net kilowatt hour reduction on an electricity bill.

PowerSaver benefits to user:

- Increases electrical capacity
- Cools overheated lines and panels
- Lowers KW consumption and demand
- Improves facility power factor
- Eliminates power factor penalties
- Lasts for 140,000 hours of service
- Improves facility voltage
- Extends the life of motors

The LightSaver Power Savings System

The LightSaver are not applicable in every situation. But when called for they will effectively reduce the watts consumed in treated lights by 10% - 40%. The LightSaver fools the light by modifying the sine wave. By cutting out the leading edges the controller effectively continues to give the light the voltage it needs but using less watts in the process.

The LightSaver can work with all type of lighting systems including fluorescent, incandescent, and all types of HID including, Sodium, Metal Halide, and Mercury Vapour. The LightSaver can interface with dedicated lighting circuits in voltages of 120, 277, 240 or 347 and amperages up to 20 amps per circuit.

Refrigeration & Air Conditioning Oil Additives

One of the simplest yet most effective treatments we may recommend is the addition of special patented, halogenated hydrocarbon additives to refrigeration and air conditioning systems, including chillers and heat pumps. Proven in hundreds of installations during the last 15 years, these special additives reduce friction on moving parts giving new life to bearings, seals and compressor parts. Reducing the friction in the system improves the compressors mechanical efficiency and lowers electrical consumption. You will immediately notice increased cooling

capacity and a quieter compressor. Best of all, you'll notice the savings on your electric bill. This treatment alone can save 10-15% on the electric use of the treated system.

Refrigeration Enhancement Systems

Another treatment often recommended by us either as a stand alone or in conjunction with other treatments, utilizes a vortex through a fixed impeller to reduce the load on the compressor. The device is an add-on for air cooled condensers. It not only increases the cooling efficiency of the unit but also reduces the pressure in the system, reducing energy cost and extending the productive life of refrigeration system compressors, saving additional money on maintenance and parts replacement.

Air Conditioning Controllers

The patented controller works on any air conditioning unit with a hermetically sealed compressor, even anything from a window unit to a 10 ton unit and larger. A smart logic circuit in the controller maintains the air conditioner at maximum efficiency. Unlike alternative air conditioner controllers that are time or movement activated, the controller has a dew point sensor installed adjacent to the condenser that turns the air conditioner off once the dew point has been reached. This is the most exact way to insure no electricity is wasted because air will not be cooled beyond the dew point even if the air conditioner is operating on maximum cold and full blower fan. Alternative types of controllers fall short of achieving maximum savings because their arbitrary shutoff criteria still allows the air conditioner to be running past the point that it is possible to continue cooling the air. We recommended air conditioning controllers typically save 15-25% on the air conditioning portion of the electric bill.

Vending Machine Controllers

Although you generally would not think of vending machines as large electricity consumers, they are on 24/7 and over a year can run up a significant bill. In low to medium traffic areas, we will recommend infrared activated controllers for cold vending machines. Endorsed by over 100 Utility companies and installed at over 100 Universities and schools, these controllers save an average of 46% on the cost of running a vending machine while still maintaining the usual and expected cold temperature for the dispensed soft drinks and juices.

Daylighting Sensors

Many rooms with south facing windows have more than adequate light during the day on most days, provided free by the sun. In such rooms an inexpensive, fast payback treatment is the installation of Daylight Sensors that keep lights off when ambient light is sufficient and automatically turn the lights on during working hours if natural daylight light levels fall below a specified threshold.

Occupancy Sensors

Many rooms are frequently unoccupied with lights or other equipment inadvertently left on even when the room is empty. During our Site Survey we will note rooms with infrequent use such as lunch rooms and recommend Occupancy Sensors. The sensors will power down or turn lights and equipment off when the room is unoccupied and bring things back to full power as soon as someone enters the room.

Transient Voltage Surge Suppression (TVSS)

TVSS systems primary purpose is to protect valuable equipment from harmful energy spikes. Many TVSS products offer little or no energy savings as they have high spike tolerances and are infrequently activated. However TVSS

products that operate on low spike tolerance keep voltage in check continually and can cut a facilities electric bill substantially while also protecting critical and sensitive equipment such as:

- ➔ Computer Systems
- ➔ Variable Frequency Drives
- ➔ Fluorescent Lighting and Ballasts
- ➔ Solid State Transmitters
- ➔ R.F. Equipment
- ➔ Irrigation Systems
- ➔ Medical Equipment
- ➔ HVAC Systems
- ➔ Audiovisual Equipment
- ➔ Security Systems
- ➔ All Electrical Equipment

Transients and power surges can come from the utility grid as well as from inside your electrical system. Small surges can occur multiple times a day to thousands of times per hour, ranging from several thousand volts to under 100 volts. Activities by your Utility company such as switching can also cause powerful surges which may be carried along utility lines. When the surge reaches your facility it may still have enough energy to jump across switches, even those which are turned off, and damage your electrical equipment.

Power surges can also be generated by your equipment within the facility and some of the equipment actually destroy themselves from the transient surges and voltage fluctuations they create. Harmful surges can be caused by:

- ➔ Elevators
- ➔ Pumps
- ➔ Office Machines
- ➔ HVAC Equipment
- ➔ Electric Motors
- ➔ Emergency Supply Transfer Switches

You can greatly increase the operating efficiency and life of your equipment and provide local, decentralized power conditioning for your critical equipment by installing TVSS at the equipment's energy source. Icing on the cake is that you can also save electricity. Maximum protection can be gained for your heavy duty equipment by installing TVSS at the main electrical panel and sub-panels for this equipment.

Active Harmonic Filters

These are electronic devices which can be suitably installed at selected points in a building or industrial plant electrical distribution system which will approximately cancel harmonics. Harmonics are normally caused by loads such as printers, computers, variable speed drives, MRI units, and other nonlinear operational devices. In some cases the harmonics can lead to large circulating currents, reduced transformer and electric cable capacity for normal loads, and the cause of nuisance breaker trippings. In extreme cases, harmonics can burn up the neutral of power distribution systems, leading to unscheduled outages of power.

Active Harmonic Filter can eliminate the harmful harmonics, balance the 3-phase current, correct power factor and save energy. Energy savings can vary substantially, depending on the level of harmonics, which must be measured; KWH savings can vary from 1-2% up to 10-15% in extreme situations.

Reference List - Partial Installation and Trial Run

- ☑ Puerto Sol Resort Hotel, Mallorca, Spain
- ☑ Davis Technological Solutions, US
- ☑ Schindler Elevator Corporation, US
- ☑ Ingersoll-Dresser Pumps, Chesapeake, VA, US
- ☑ Las Vegas Casino, US
- ☑ The American Club, SIN
- ☑ HDB Flat, SIN
- ☑ Microtac Technologies, SIN
- ☑ US Navy Base, SIN
- ☑ Armstrong, SIN
- ☑ STM, SIN
- ☑ OPA-SPF, SIN
- ☑ Prima, SIN
- ☑ Country Club, SIN
- ☑ Condominium, SIN
- ☑ DVD manufacture, Malaysia
- ☑ CosmoPlas, Malaysia
- ☑ KBF Synergy, Malaysia
- ☑ Auto Synergy, Malaysia
- ☑ Condominium, Malaysia
- ☑ Ciba, Indonesia
- ☑ Liao He Oil Field, China
- ☑ Saint-Gobain, China
- ☑ Sichang Hardware, China
- ☑ Zhujiang Plastic, China
- ☑ Mubiao Technologies, China
- ☑ Shenghua Machinery, China
- ☑ And more

**AEIC SOLUTIONS provides you total energy saving solutions
to protect your systems, lower your electricity bill,
and benefit to environment and earth.**

